



Yamaha YZF R1 (2004 - 2006)

Slip-On Exhaust System

Akrapovic Slip-On Exhaust System

for the Yamaha YZF R1 (2004 - 2006)

For the 2004 Yamaha R1 we present a basic version of the Akrapovic SLIP-ON exhaust system with two mufflers and two link pipes. We have also developed an extended version with an optional Y- connecting tube. The basic Akrapovic SLIP-ON system allows the use of the stock catalytic converter. The version with the optional Y- connecting tube extends past the point where the catalytic converter is located, so that the catalytic converter is removed. There is no major difference in performance between the two systems. However, they both outperform the stock system in both power and torque. The system is intended for riders who do not wish to make major exhaust system modifications. In addition to the Slip-On (open) also Slip-On Street Legal and Slip-On SP Series systems are available.

PERFORMANCE

Measurements of the Akrapovic SLIP-ON system on the YAMAHA YZF R1 (without optional Y-connecting tube and muffler insert):

Power & Torque: performance measurements were made on both systems. The difference is minimal, with the advantage going to the option with the optional Y-connecting tube, which is slightly better in the middle of the rpm range. There is also a slight difference at the top end, but this does not affect the riding characteristics. Despite being only a first-stage tuning component, the system adds quite a bit of power to the stock engine figures. The standard option without the Y-connecting tube puts out 159.6 HP at 12800 rpm. The option with the optional Y-connecting tube was measured at 159.4 HP at 12700 rpm. The torque curves of the two options are also very similar. There is a significant increase over the stock torque curve, especially above 6000 rpm.

CONFIGURATION

The basic configuration of the Akrapovic SLIP-ON system for the Yamaha R1 is as follows: the system includes two mufflers, either titanium or carbon-fiber, attached under the seat with carbon-fiber clamps. Slip-On (open) and Slip-On Street Legal system muffler outlet caps are made of carbon-fiber while Slip-On SP Series system muffler outlet caps are made of titanium.

The cylindrical link pipes are made of titanium and are welded to the mufflers. The connections of the link pipes to the stock header assembly are sleeve joints secured with metal clamps. The system uses the stock catalytic converter.

The Y-connecting tube can be ordered as an option, which expands the basic configuration as follows: The basic system continues with the optional Y- connecting tube, which is conical and made of stainless steel. The Akrapovic Y-connecting tube replaces the stock Y- connecting tube where the catalytic converter is located. The catalytic converter cannot be mounted in the Akrapovic Y- connecting tube. The link pipes and the Y-connecting tube are attached with sleeve joints secured with metal tensioning springs, as is the joint between the Y-connecting tube and the collector.

	PERFORMANCE		
	stock	AKRAPOVIC	max. increased power
max. rear wheel power HP / rpm (measured on Dynojet ATV)	157.9 / 12770	159.6 / 12800 159.4 / 12700 (with Y- connecting tube)	4 / 8400 5.4 / 8360 (with Y- connecting tube)

	CONFIGURATION			
	header tubes	collector	Y-connecting tube	link pipe
material	-	-	STAINLESS STEEL	TITANIUM
tube shape	-	-	CONICAL	CYLINDRICAL

interference crossover tubes	-	lambda sensor	YES
header tube inner sleeves	-	header tube flanges	-
header tubes - collector connection	-	collector / header tube - link pipe connection	SLEEVE JOINT + METAL CLAMPS
link pipe - muffler connection	WELDED	muffler inlet cap /outlet cap	TITANIUM / CARBON-FIBER (open + Street Legal), TITANIUM (SP Series)
muffler metal interior	TITANIUM	muffler outer sleeve	TITANIUM / CARBON-FIBER
muffler clamp	CARBON-FIBER ROAD	muffler bracket	-
muffler insert	EU	NOISE DAMPER	heat shield
	US	-	catalytic converter

	ADDITIONAL DATA				
	stock	AKRAPOVIC		difference	
weight comparison (kg)	4.12 5.56 (with Y- connecting tube)	S.S. link pipe	TITANIUM link pipe	stock - S.S.	stock - titanium
		-	3.20 3.80 (with Y- connecting tube)	0.00	0.92 1.76 (with Y- connecting tube)
noise measurements (dB / rpm)	stock		AKRAPOVIC		
	97 / 6250		97 / 6250 (Street Legal + SP series homologated) 100.9 / 6250 (open)		
possibility of periodic service without removing A.E.S.	oil		oil filter		
	YES		YES		
legal for street use	YES (Street Legal + SP Series homologated)				

Technical specifications of Akrapovic exhaust systems and related products subject to change without notice.

Product code: 106074 (S-Y10SO6-DTC/1), 106075 (S-Y10SO6-DTT/1)
106080 (S-Y10SO6-HDTC/1), 106081 (S-Y10SO6-HDTT/1) homologated

Akrapovic Slip-On Exhaust System for the Yamaha YZF R1 (2004 - 2006)



CARBON-FIBER
MUFFLER CLAMPS

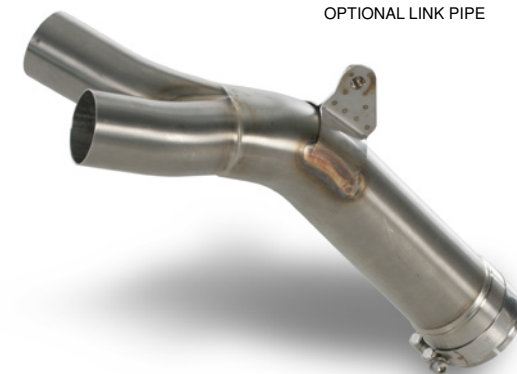

OPTIONAL LINK PIPE

Product code: 106074 (S-Y10SO6-DTC/1), 106075 (S-Y10SO6-DTT/1)
106080 (S-Y10SO6-HDTC/1), 106081 (S-Y10SO6-HDTT/1) homologated

Akrapovic Slip-On Exhaust System for the Yamaha YZF R1 (2004 - 2006)



Akrapovic Exhaust System Technology copyright 2006, all rights reserved

Road
Program

Product code: 106074 (S-Y10SO6-DTC/1), 106075 (S-Y10SO6-DTT/1)
106080 (S-Y10SO6-HDTC/1), 106081 (S-Y10SO6-HDTT/1) homologated

Akrapovic Slip-On Exhaust System for the Yamaha YZF R1 (2004 - 2006)



Akrapovic Exhaust System Technology copyright 2006, all rights reserved

Road Program

Product code: 106074 (S-Y10SO6-DTC/1), 106075 (S-Y10SO6-DTT/1)
106080 (S-Y10SO6-HDTC/1), 106081 (S-Y10SO6-HDTT/1) homologated

Akrapovic Slip-On Exhaust System

for the Yamaha YZF R1 (2004 - 2006)

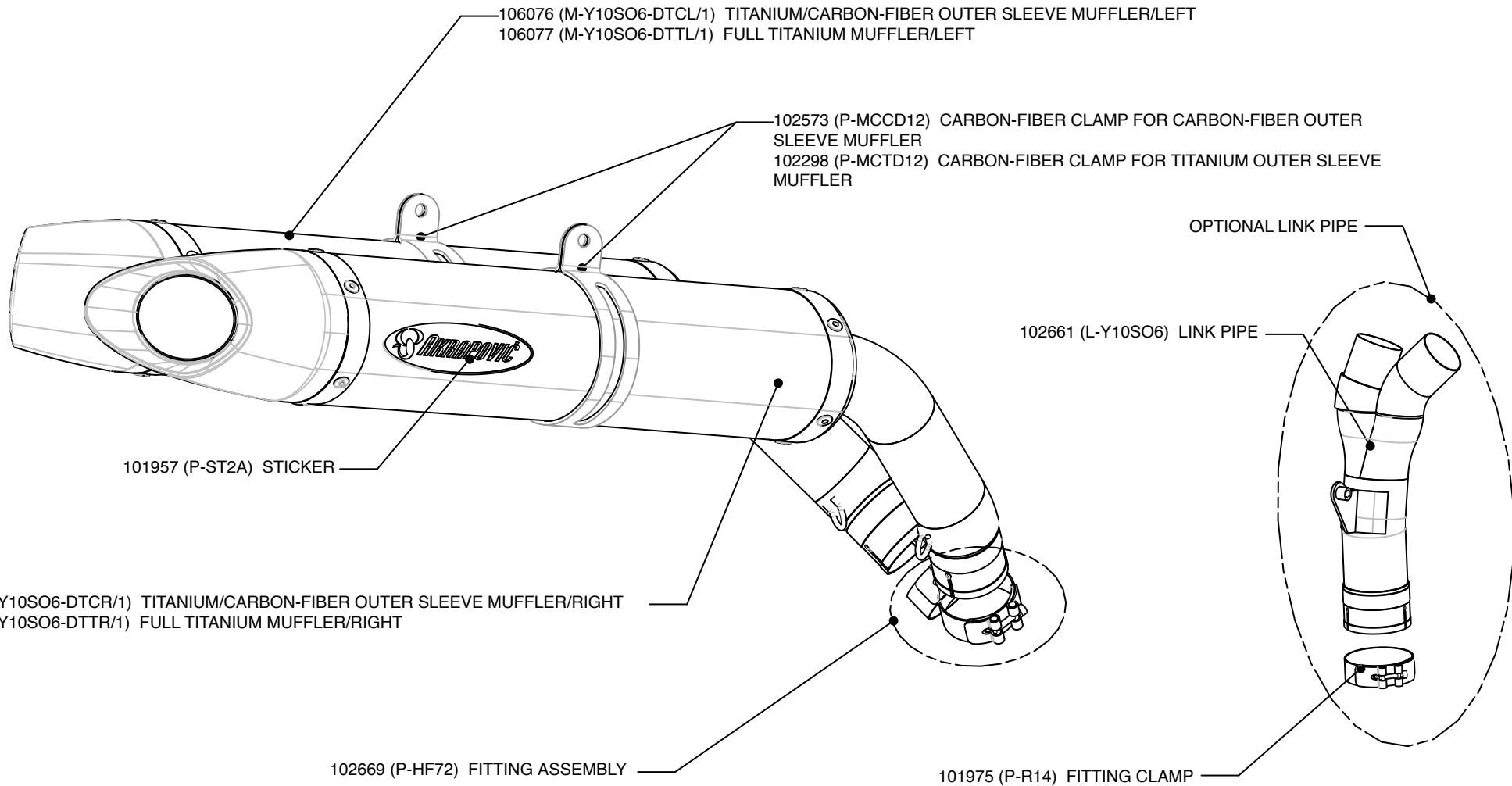

Product code: 106074 (S-Y10SO6-DTC/1), 106075 (S-Y10SO6-DTT/1)

Akrapovic Slip-On Exhaust System for the Yamaha YZF R1 (2004 - 2006)

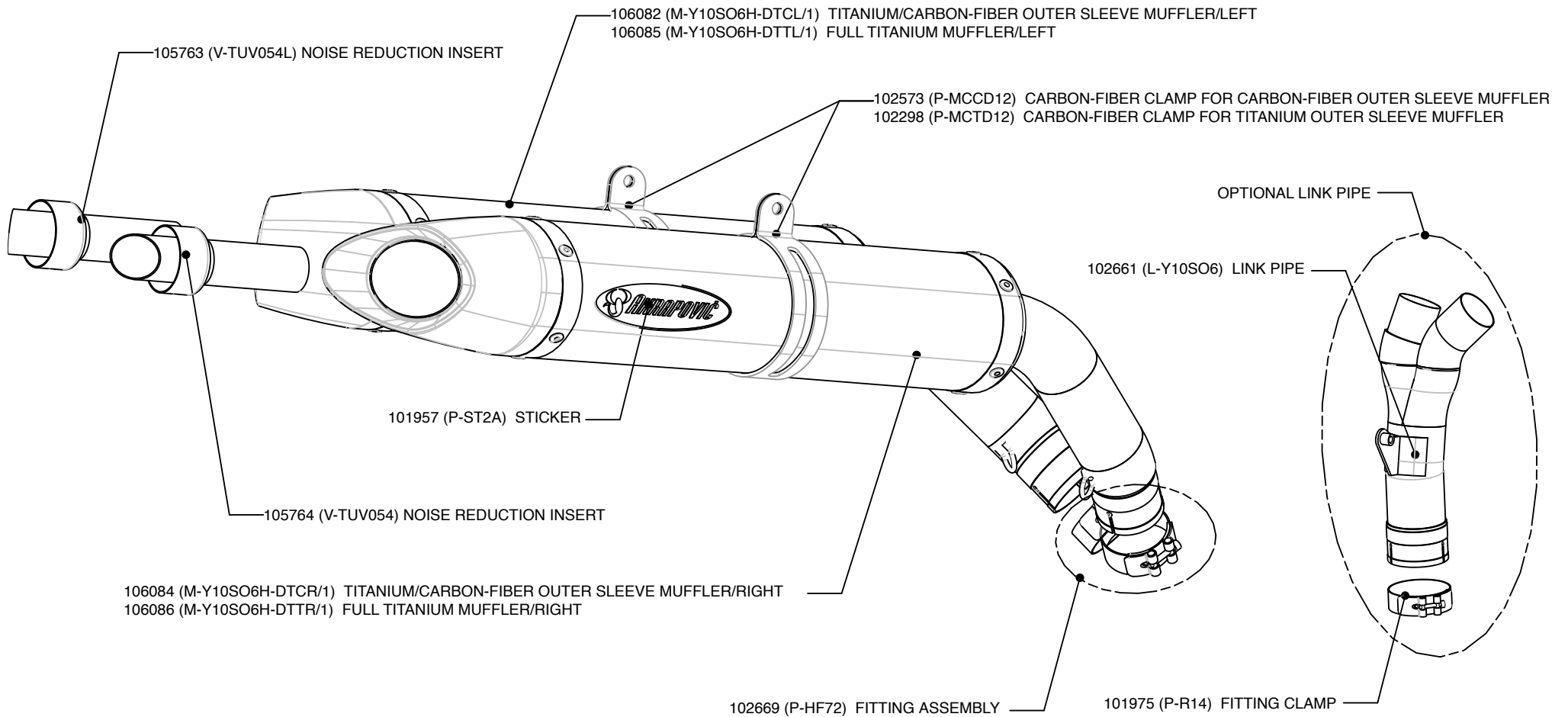

Akrapovic Exhaust System Technology copyright 2006, all rights reserved

Road Program

Product code: 106080 (S-Y10SO6-HDTC/1), 106081 (S-Y10SO6-HDTT/1) homologated



Akrapovic Slip-On Exhaust System for the Yamaha YZF R1 (2004 - 2006)

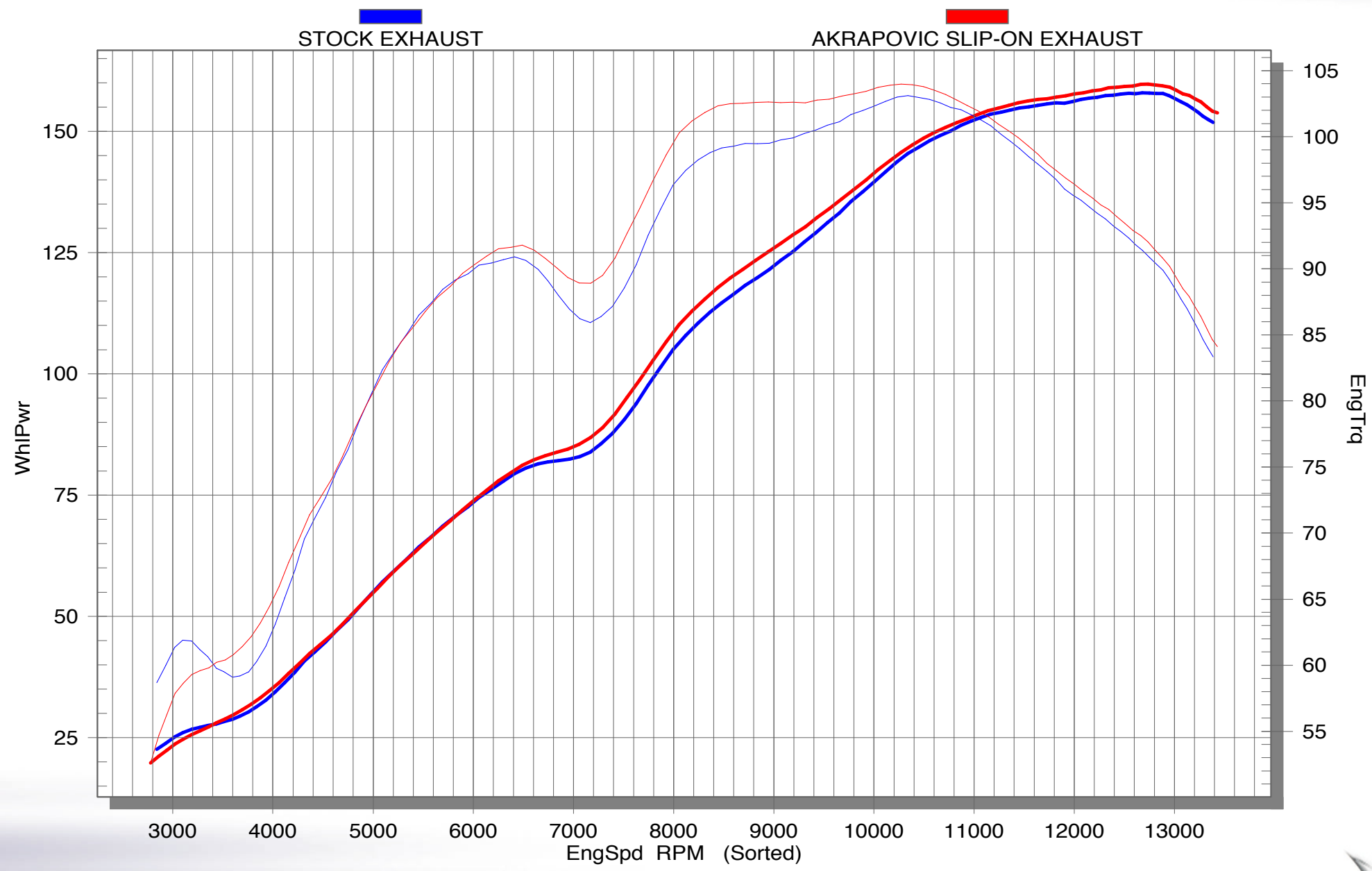

Road Program

Product code: 106074 (S-Y10SO6-DTC/1), 106075 (S-Y10SO6-DTT/1)
106080 (S-Y10SO6-HDTC/1), 106081 (S-Y10SO6-HDTT/1) homologated



Akrapovic Exhaust System Technology copyright 2006, all rights reserved

Akrapovic Slip-On Exhaust System for the Yamaha YZF R1 (2004 - 2006)

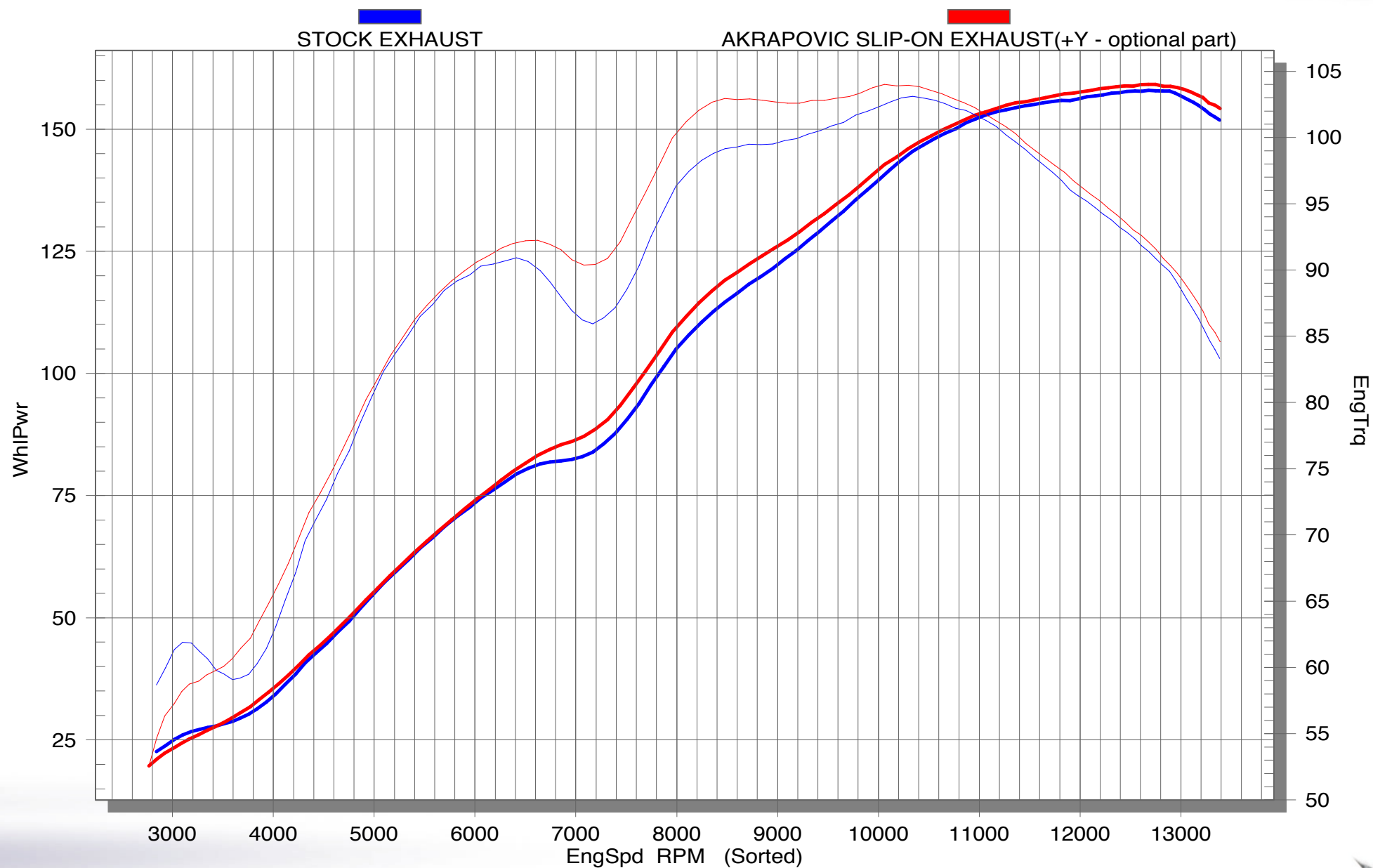

Road Program

Product code: 106074 (S-Y10SO6-DTC/1), 106075 (S-Y10SO6-DTT/1)
106080 (S-Y10SO6-HDTC/1), 106081 (S-Y10SO6-HDTT/1) homologated

